

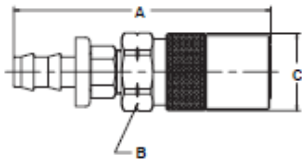

MOLDMATE SERIES QUICK COUPLINGS

Couplers

Straight



Body Size (in.)	Part No. Brass Non-valved	Wt. (LB.) P/Piece	Part No. Brass Valved	Wt. (LB.) P/Piece	Hose I.d.	Dimensions (in.)					
						Overall Length	Largest Diameter		Overall Length	Hex Size Diameter	
							A	B		C	A
1/4	PC204	0.10	PC204AV	0.10	1/4	1.87	0.63		2.67	0.63	0.71
1/4	PC204-BP*	0.10	PC204AV-BP	0.10	1/4	1.89	0.63		2.52	0.63	0.71
1/4	PC205	0.09	PC205AV	0.10	5/16	1.87	0.63		2.67	0.63	0.71
1/4	PC206	0.09	PC206AV	0.10	3/8	1.87	0.63		2.67	0.63	0.71
1/4	PC206-BP*	0.11	PC206AV-BP	0.13	3/8	2.04	0.63		2.70	0.63	0.71
3/8	PC306	0.24	PC306V	0.27	3/8	3.01	0.96		3.17	0.88	1.01
3/8	PC306-BP*	0.26	PC306V-BP	0.29	3/8	3.15	0.96		3.31	0.88	1.01
3/8	PC308	0.25	PC308V	0.28	1/2	3.15	0.96		3.17	0.88	1.01
3/8	PC308-BP*	0.25	PC308V-BP	0.03	1/2	3.27	0.96		3.43	0.88	1.01
1/2	PC504	0.46	NA	-	1/2	3.55	1.30		-	-	-
1/2	PC504-BP*	0.50	NA	-	1/2	3.68	1.21		-	-	-
1/2	PC506	0.48	NA	-	3/4	3.80	1.21		-	-	-
1/2	PC506-BP*	0.52	NA	-	3/4	3.80	1.21		-	-	-

NA = Not Available

45 Degree

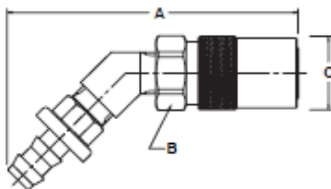

Body Size (in.)	Part No. Brass Non-valved	Wt. (LB.) P/Piece	Part No. Brass Valved	Wt. (LB.) P/Piece	Hose I.D.	Dimensions (in.)							
						Overall Length	Hex Size	Largest Diameter		Overall Length	Hex Size	Largest Diameter	
								A	B			C	A
1/4	PC224	0.13	PC224AV	0.13	1/4	2.67	0.56	0.71	2.87	0.63	0.71		
1/4	PC224-BP*	0.13	PC224AV-BP	0.14	1/4	2.57	0.56	0.71	2.77	0.63	0.71		
1/4	PC226	0.13	PC226AV	0.14	3/8	2.71	0.56	0.71	2.91	0.63	0.71		
1/4	PC226-BP*	0.26	PC226AV-BP	0.17	3/8	2.74	0.56	0.71	2.94	0.63	0.71		
3/8	PC326	0.36	PC326V	0.36	3/8	3.65	0.88	0.96	3.65	0.88	1.01		
3/8	PC326-BP*	0.34	PC326V-BP	0.36	3/8	3.75	0.88	0.96	3.75	0.88	1.01		
3/8	PC328	0.36	PC328V	0.36	1/2	3.69	0.88	0.96	3.69	0.88	1.01		
3/8	PC328-BP*	0.34	PC328V-BP	0.40	1/2	3.88	0.88	0.96	3.88	0.88	0.96		
1/2	PC524	0.74	NA	-	1/2	4.18	1.12	1.21	-	-	-		
1/2	PC524-BP*	0.78	NA	-	1/2	4.28	1.12	1.21	-	-	-		
1/2	PC526	0.76	NA	-	3/4	4.56	1.12	1.21	-	-	-		
1/2	PC526-BP*	0.80	NA	-	3/4	4.56	1.12	1.21	-	-	-		

* Suffix BP in part number denotes Push-Lok hose barb. Without suffix denotes standard hose barb. Push-Lok hose barbs are designed for use with Parker Push-Lok hose and do not require clamps. Valved Couplers can be used with either non-valved or valved nipples.

Replacement Seals (for both Valved and Non-valved)

Seal Material	Body Size (in.) 1/4	Body Size (in.) 3/8	Body Size (in.) 1/2
* Silicone	P200-9A	P300-9A	P500-9A
* Fluorocarbon	P200-9AY	P300-9AY	—

* Please note: Bulk seals are considered to be non-returnable.

90 Degree

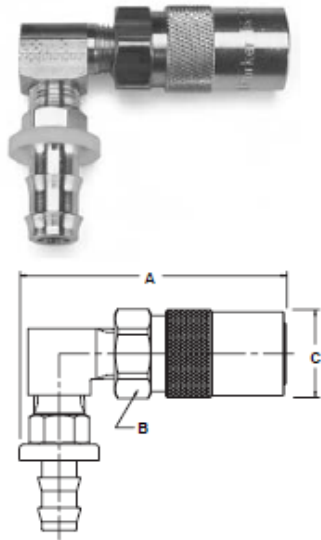

Body Size (in.)	Part No. Brass Non-valved	Wt. (LB.) P/Piece	Part No. Brass Valved	Wt. (LB.) P/Piece	Hose I.D.	Dimension (in.)			Dimensions (in.)		
						Overall Length	Hex Size	Largest Diameter	Overall Length	Hex Size	Largest Diameter
						Non-valved			Valved		
						A	B	C	A	B	C
1/4	PC214	0.13	PC214AV	0.14	1/4	1.78	0.56	0.71	1.98	0.63	0.71
1/4	PC214-BP*	0.14	PC214AV-BP	0.14	1/4	1.78	0.56	0.71	1.98	0.63	0.71
1/4	PC215	0.13	PC215AV	0.14	5/16	1.78	0.56	0.71	1.98	0.63	0.71
1/4	PC216	0.14	PC216AV	0.15	3/8	1.78	0.56	0.71	1.98	0.63	0.71
1/4	PC216-BP*	0.16	PC216AV-BP	0.17	3/8	1.80	0.56	0.71	2.00	0.63	0.71
3/8	PC316	0.31	PC316V	0.31	3/8	2.78	0.88	0.96	2.78	0.88	0.96
3/8	PC316-BP*	0.37	PC316V-BP	0.37	3/8	2.78	0.88	0.96	2.78	0.88	0.96
3/8	PC318	0.33	PC318V	0.35	1/2	2.78	0.88	0.96	2.78	0.88	0.96
3/8	PC318-BP*	0.37	PC318V-BP	0.39	1/2	2.80	0.88	0.96	2.80	0.88	0.96
1/2	PC514	0.79	NA	-	1/2	3.50	1.12	1.21	-	-	-
1/2	PC514-BP*	0.83	NA	-	1/2	3.50	1.12	1.21	-	-	-
1/2	PC516	0.80	NA	-	3/4	3.50	1.12	1.21	-	-	-
1/2	PC516-BP*	0.84	NA	-	3/4	3.50	1.12	1.21	-	-	-

* Suffix BP in part number denotes Push-Lok hose barb. Without suffix denotes standard hose barb. Push-Lok hose barbs are designed for use with Parker Push-Lok hose and do not require clamps. Valved Couplers can be used with either non-valved or valved nipples.

Nipples

Female Pipe Thread

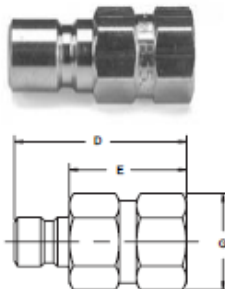

Body Size (in.)	Part No. Brass	Wt. (LB.) P/Piece Brass	Part No. Steel	Wt. (LB.) P/Piece Steel	Thread Size NPTF	Dimensions (in.)			
						Overall Length	**Exposed Length	Hex Size	Largest Diameter
						D	E	F	G
1/4	BPN251F	0.02	PN251F	0.02	1/8-27	0.97	0.58	0.50	0.58
1/4	BPN252F	0.05	PN252F	0.04	1/4-18	1.28	0.89	0.63	0.72
1/4	BPN253F	0.08	PN253F	0.08	3/8-18	1.41	1.02	0.75	0.87
3/8	BPN352F	0.05	PN352F	0.05	1/4-18	1.48	0.88	0.63	0.72
3/8	BPN353F	0.07	PN353F	0.06	3/8-18	1.58	0.98	0.75	0.87

Male Pipe Thread

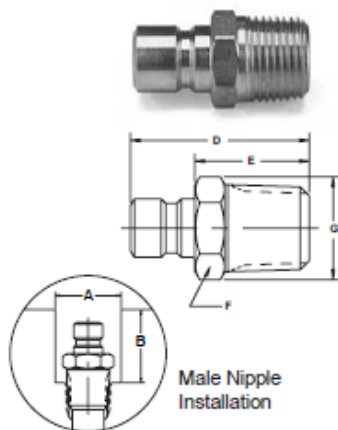

Body Size (in.)	Part No. Brass	Wt. (LB.) P/Piece Brass	Part No. Steel	Wt. (LB.) P/Piece Steel	Thread Size NPTF	Dimensions (in.)				Installation	
						Overall Length	**Exposed Length	Hex Size	Largest Dia.	Recess Dia.	Depth
						D	E	F	G	A	B
1/4	PN250	0.02	-	-	1/16-27	0.94	0.54	0.44	0.51	0.69	0.69
1/4	PN251	0.02	PN251S	0.02	1/8-27	0.94	0.54	0.44	0.51	0.69	0.69
1/4	PN252	0.03	PN252S	0.03	1/4-18	1.13	0.74	0.56	0.67	0.84	0.94
1/4	PN253	0.05	PN253S	0.05	3/8-18	1.19	0.79	0.69	0.79	1.00	0.94
3/8	PN352	0.04	PN352S	0.04	1/4-18	1.34	0.74	0.56	0.65	1.00	1.09
3/8	PN353	0.06	PN353S	0.06	3/8-18	1.38	0.78	0.69	0.79	1.00	1.13
3/8	PN354	0.12	NA	-	1/2-14	1.59	0.99	0.88	1.01	1.19	1.25
1/2	PN553	0.12	NA	-	3/8-18	1.53	0.77	0.88	1.01	1.25	1.34
1/2	PN554	0.11	NA	-	1/2-14	1.70	0.94	0.88	1.01	1.25	1.50
1/2	PN556	0.16	NA	-	3/4-14	1.75	0.99	1.06	1.23	1.50	1.56

Valved Nipple

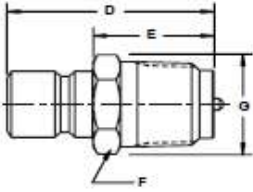

Body Size (in.)	Part No. Brass	Thread Size NPTF	Overall Length	Dimensions (in.)			Installation		Wt. (LB.) P/Piece
				**Exposed Length	Hex Size	Largest Dia.	Recess Dia.	Depth	
			D	E	F	G	A	B	
1/4	BPV252*	1/4-18	1.21	0.82	.56	0.67	0.84	0.94	0.03
3/8	BPV353*	3/8-18	1.48	0.88	.69	0.79	1.00	1.23	0.07

*Valved Nipple must be used with Valved Coupler.

**This dimension represents the portion of the nipple that is exposed when inserted into a moldmate coupler.